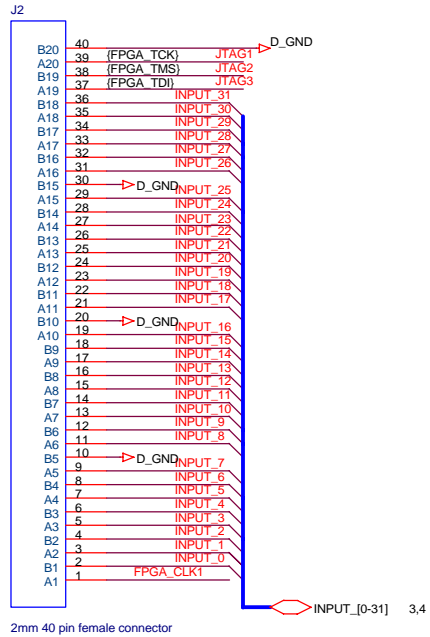

TABLE OF CONTENTS

| | |
|-----------------|------------------|
| MAIN.....1 | MICRO.....4 |
| CONNECTOR.....2 | POWER.....5 |
| FPGA.....3 | TURBO CODE.....6 |

| | | |
|---|----------------------------------|--------------|
| Christian Föhr | | |
| Mobile Satellite Services 18221A Flower Hill Way Gaithersburg, MD 20879 | | |
| Title ComBlock 7001 / MAIN | | |
| Size A | Document Number Y01012 | Rev A |
| Date: | Tuesday, December 11, 2001 | Sheet 1 of 6 |

40 Pin INPUT - Left



40 Pin OUTPUT - Bottom

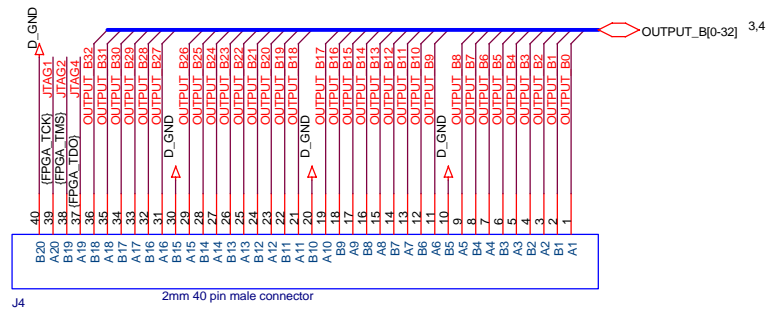

40 Pin OUTPUT - Right

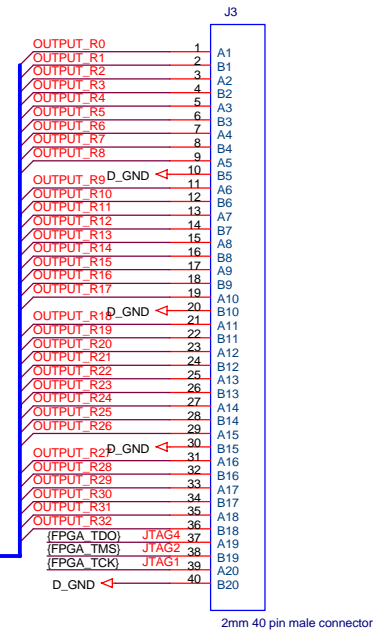

FPGA_CLK1

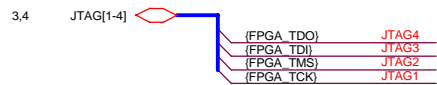
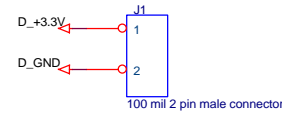

| | | |
|--|----------------------------------|----------|
| Christian Föhr | | |
| Mobile Satellite Services 18221A Flower Hill Way Gaithersburg, MD 20879 USA | | |
| Title ComBlock 7001 / CONNECTOR | | |
| Size B | Document Number Y01012 | Rev 0 |
| Date: Tuesday, December 11, 2001 | Sheet 2 | of 6 |

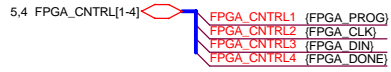
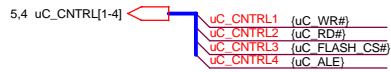

IN CIRCUIT PROGRAMMING HEADER

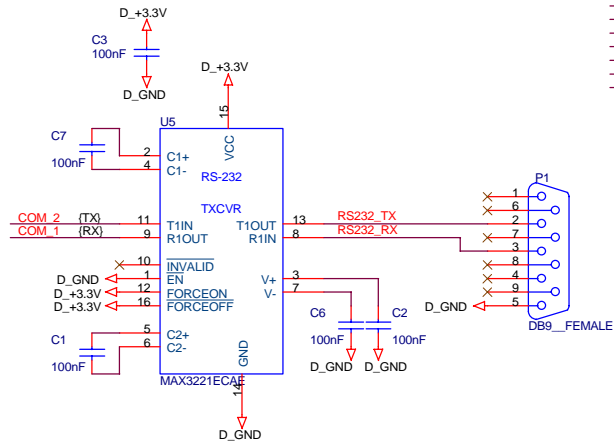
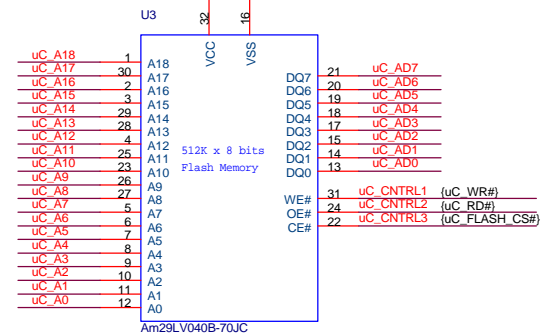
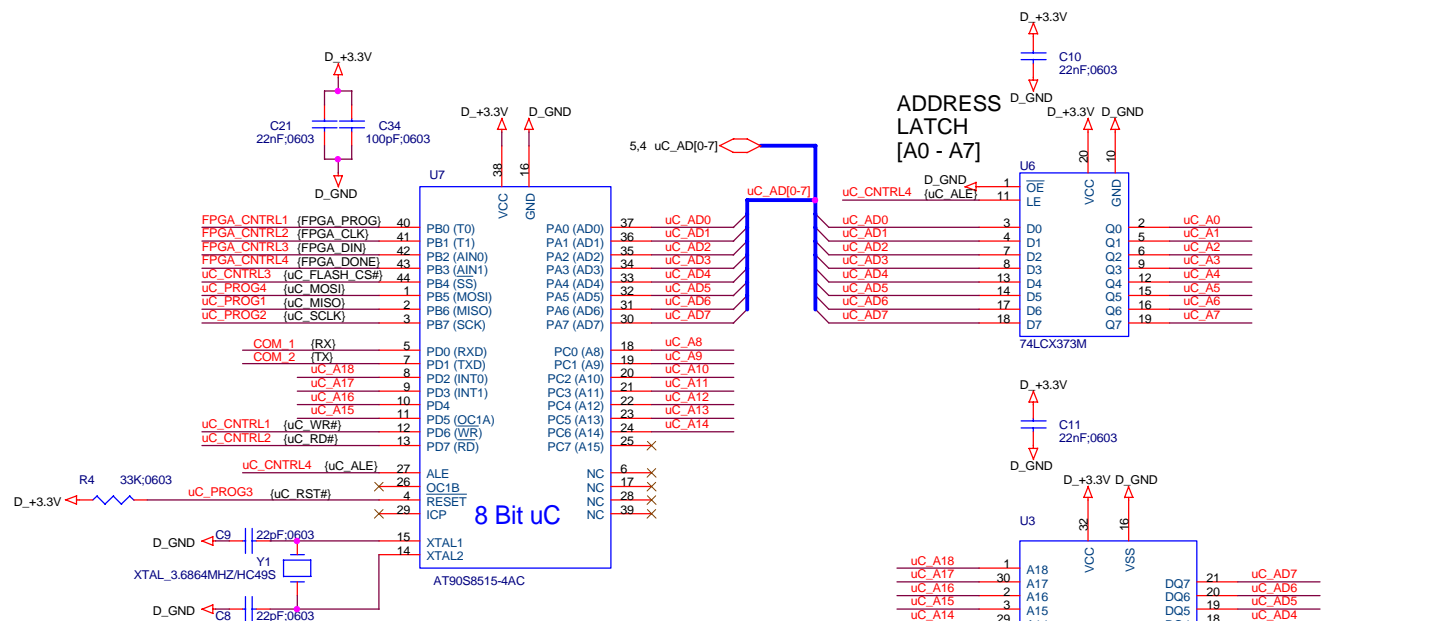
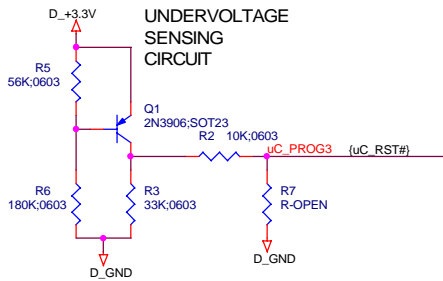
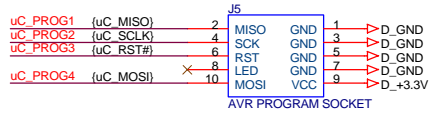

Christian Föhr
Mobile Satellite Services
18221A Flower Hill Way
Gaithersburg, MD 20879
USA

Title: **ComBlock 7001 / MICROCONTROLLER**

Size B Document Number **Y01012** Rev 0

Date: Tuesday, December 11, 2001 Sheet 4 of 6

+5 V Supply

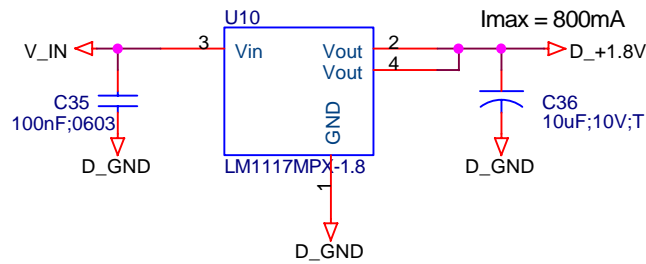
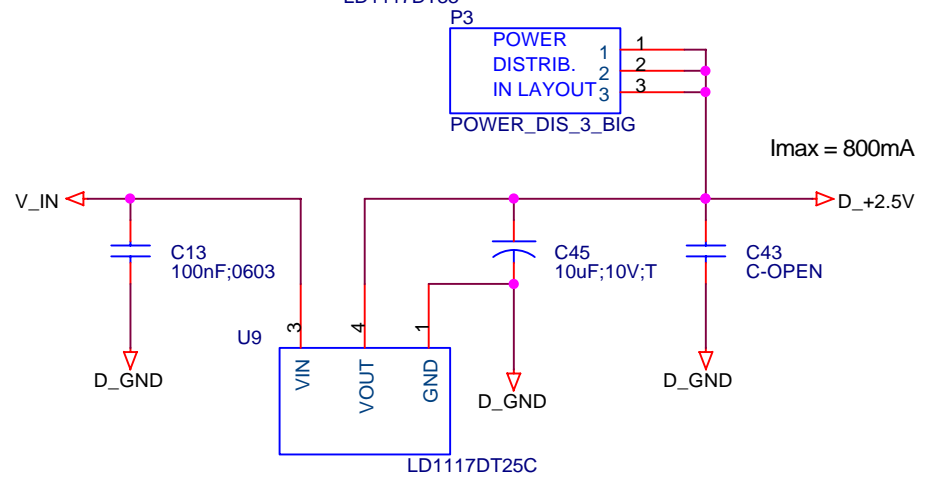
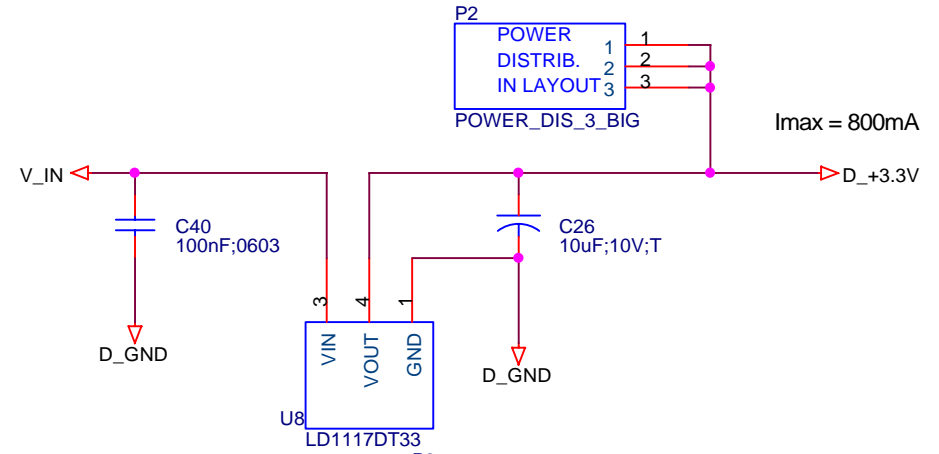
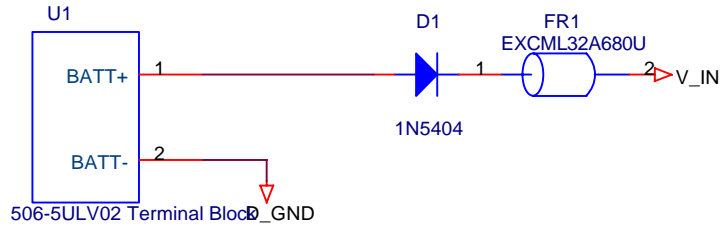

Christian Föhr
 Mobile Satellite Services
 18221A Flower Hill Way
 Gaithersburg, MD 20879
 USA

Title
ComBlock 7001 / POWER

| | | |
|-----------|----------------------------------|----------|
| Size A | Document Number Y01012 | Rev 0 |
|-----------|----------------------------------|----------|

Date: Tuesday, December 11, 2001 Sheet 5 of 6

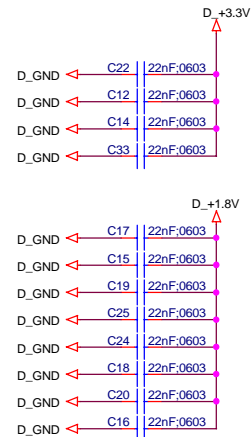
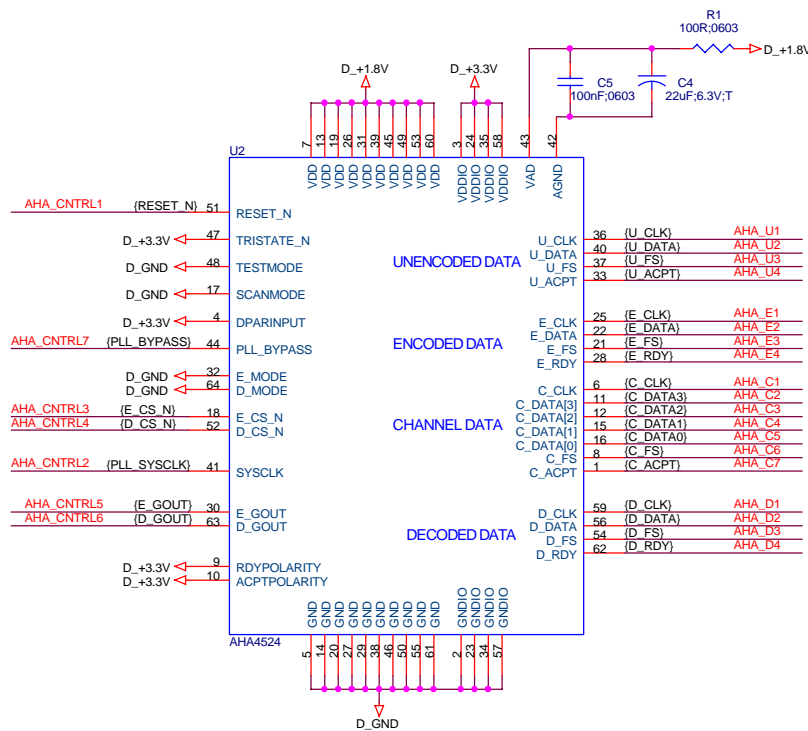
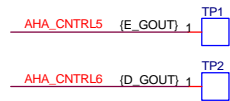
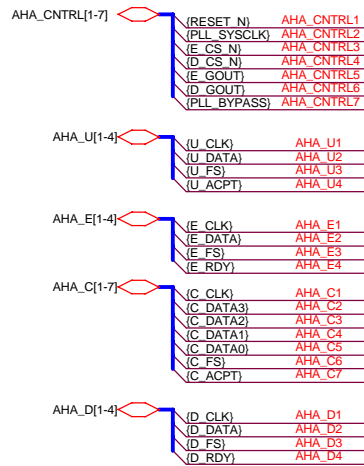

Mobile Satellite Services
 Christian K. Föhr
 18221A Flower Hill Way
 Gaithersburg, MD 20879
 USA

Title
ComBlock 7001 / TURBO CODE

Size B Document Number
Y01010 Rev 0

Date: Tuesday, December 11, 2001 Sheet 6 of 6