

TABLE OF CONTENTS

| | | | |
|----------------|---|------------|---|
| MAIN..... | 1 | LAN3..... | 5 |
| CONNECTOR..... | 2 | LAN4..... | 6 |
| LAN1..... | 3 | POWER..... | 7 |
| LAN2..... | 4 | RJ45..... | 8 |

General Layout Notes:
 - use RC0603 for all 0603
 - use RC0402 for all 0402

| | | |
|--------------------------------------------------------------------------------------|----------------------------------|----------|
| AK | | |
| Mobile Satellite Services 18221A Flower Hill Way Gaithersburg, MD 20879 USA | | |
| Title COM-5401 / MAIN | | |
| Size A | Document Number Y10002 | Rev 0 |
| Date: Monday, April 12, 2010 | Sheet 1 of 8 | |

Right Side Connector

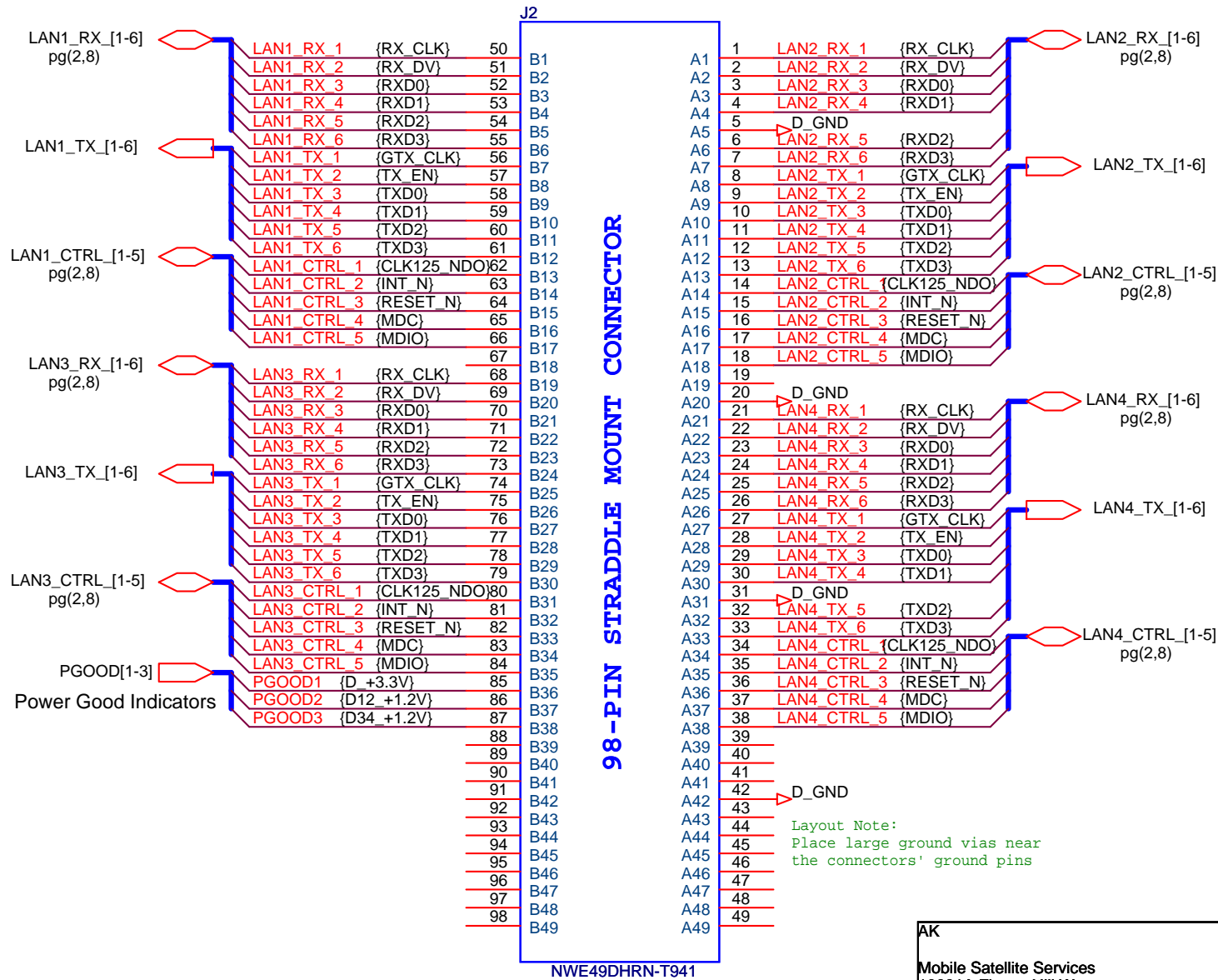

Note to User:
 'A' Nets are always on the top side physically of the PCB and 'B' on the bottom, contrary to the Right side connector's pin (not net) names.

CLK125_EN pullup for LAN1 only



| | | |
|--------------------------------------------------------------------------------------|----------------------------------|----------|
| AK | | |
| Mobile Satellite Services 18221A Flower Hill Way Gaithersburg, MD 20879 USA | | |
| Title COM-5401 / DIGITAL_CONNECTOR | | |
| Size A | Document Number Y10002 | Rev 0 |
| Date: Monday, April 12, 2010 | Sheet 2 of 8 | |

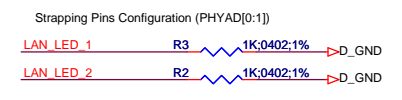
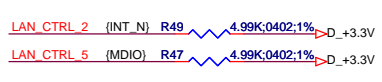
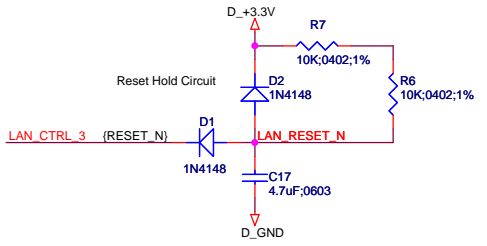
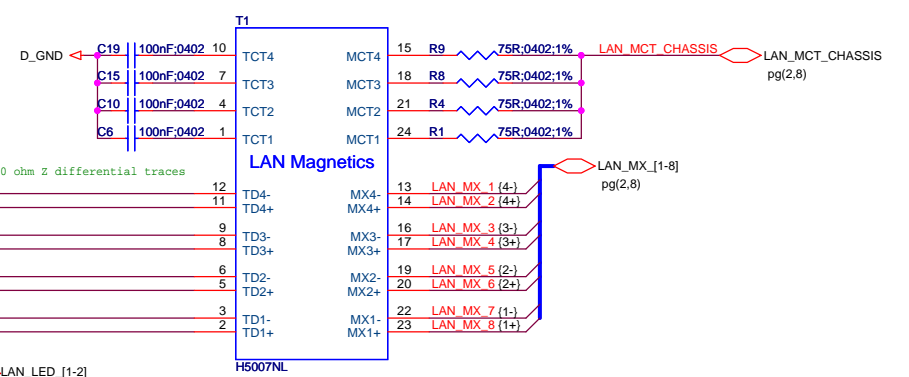
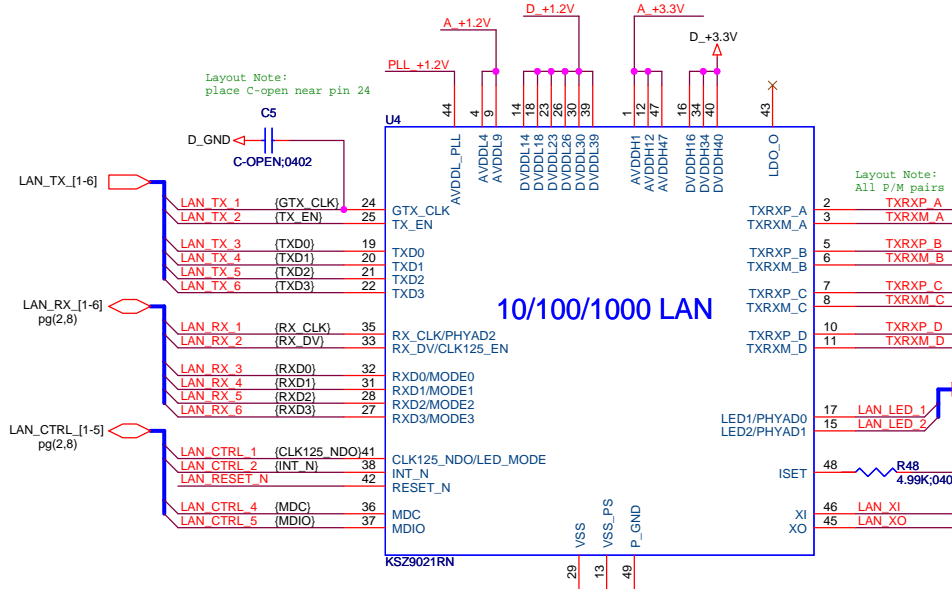
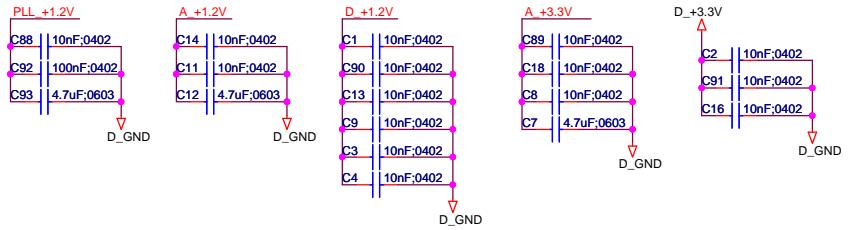
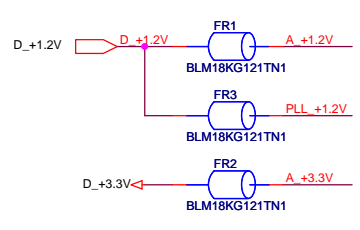

| | |
|--------------------------------------------------------------------------------------|----------------------------------|
| AK | |
| Mobile Satellite Services 18221A Flower Hill Way Gaithersburg, MD 20879 USA | |
| Title COM-5401 / LAN | |
| Size B | Document Number Y10002 |
| Date: Monday, April 12, 2010 | Sheet 3 of 8 |
| | Rev 0 |

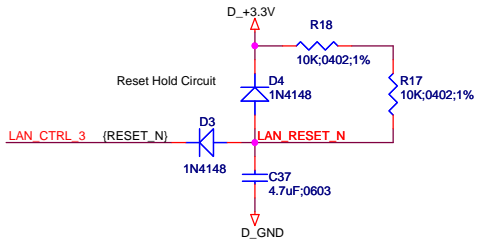
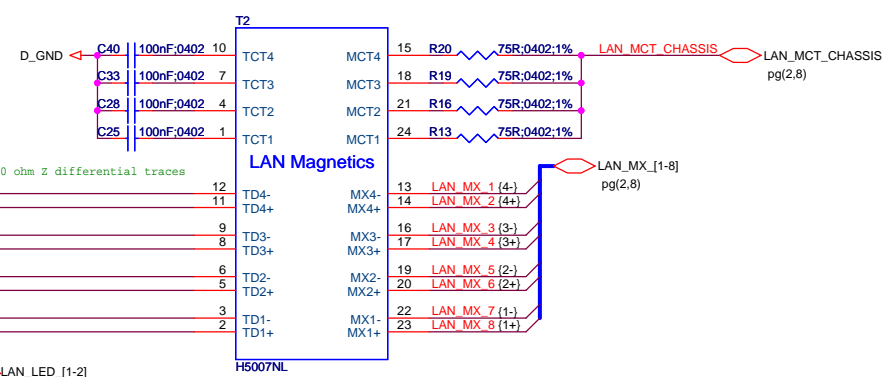
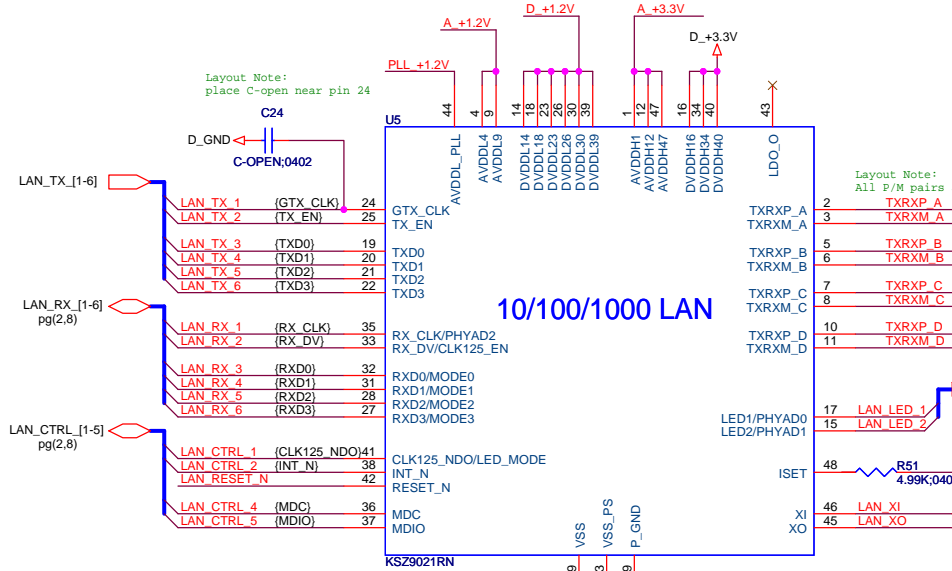
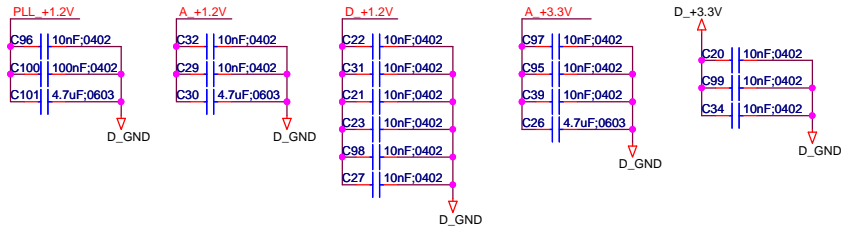
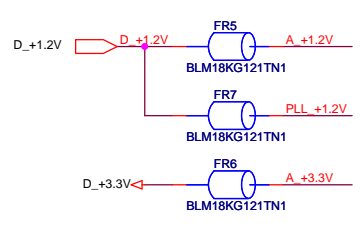

Layout Note:
All P/M pairs are 100 ohm Z differential traces

Layout Note:
place C-open near pin 24

| | | |
|--------------------------------------------------------------------------------------|----------------------------------|----------|
| AK | | |
| Mobile Satellite Services 18221A Flower Hill Way Gaithersburg, MD 20879 USA | | |
| Title COM-5401 / LAN | | |
| Size B | Document Number Y10002 | Rev 0 |
| Date: Monday, April 12, 2010 | Sheet 4 | of 8 |

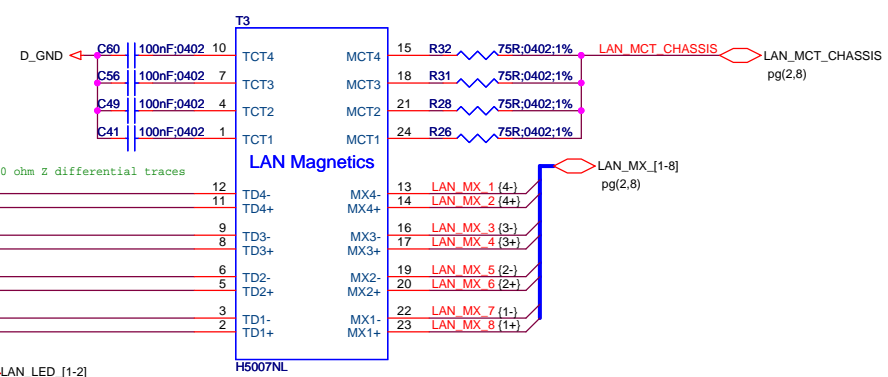
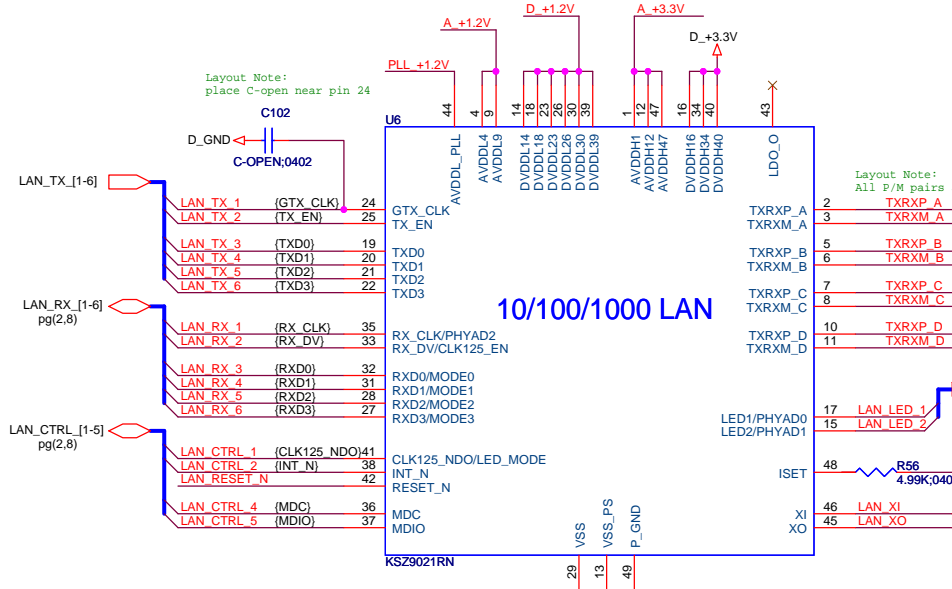
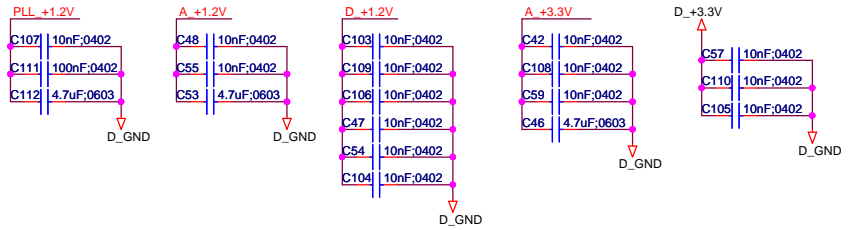
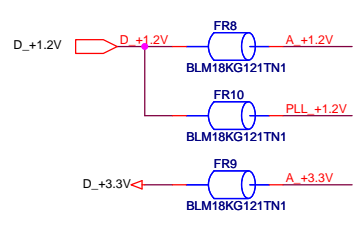

Layout Note:
place C-open near pin 24

Layout Note:
All P/M pairs are 100 ohm z differential traces

10/100/1000 LAN

LAN Magnetics

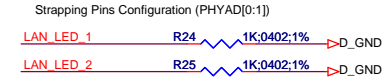
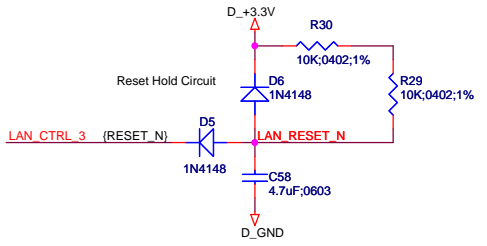

| | | |
|--------------------------------------------------------------------------------------|----------------------------------|----------|
| AK | | |
| Mobile Satellite Services 18221A Flower Hill Way Gaithersburg, MD 20879 USA | | |
| Title COM-5401 / LAN | | |
| Size B | Document Number Y10002 | Rev 0 |
| Date: Monday, April 12, 2010 | Sheet 5 | of 8 |

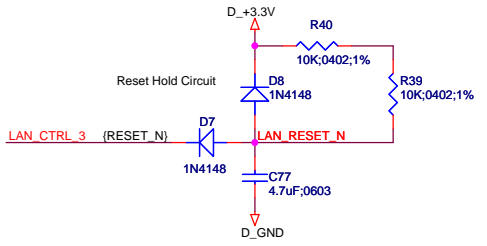
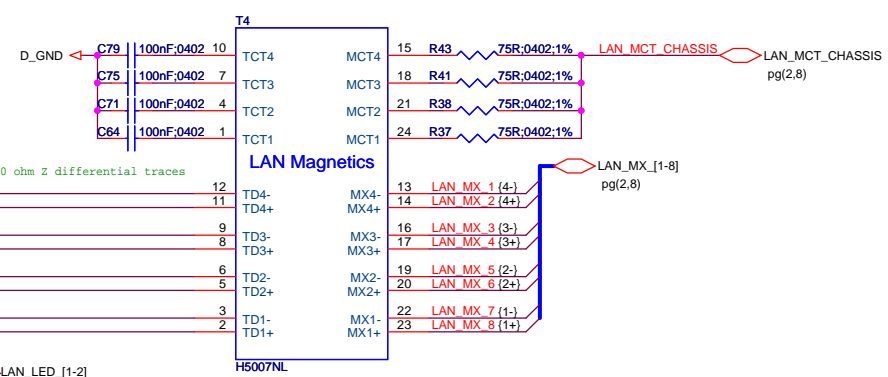
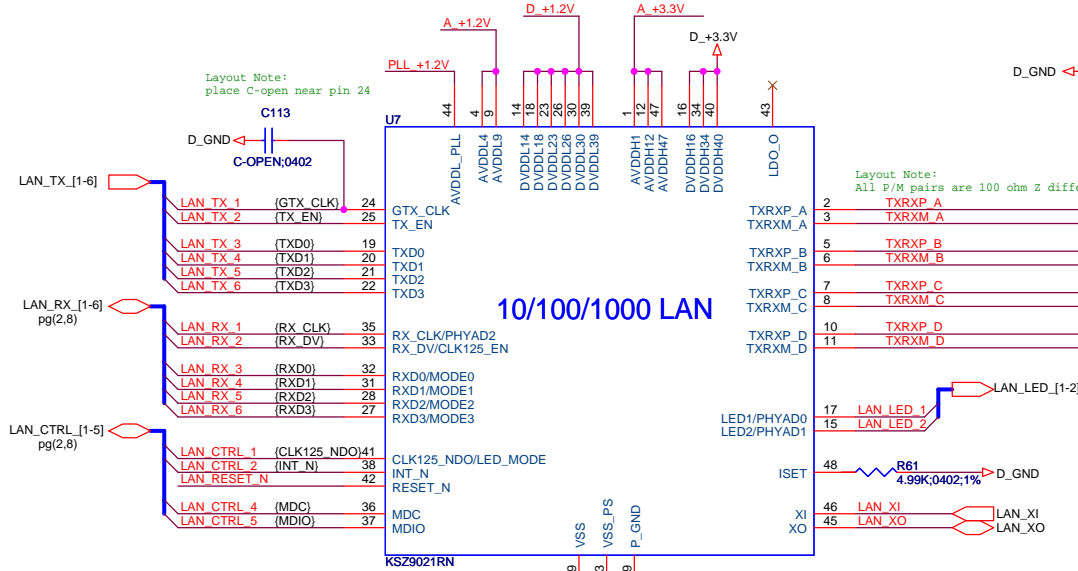
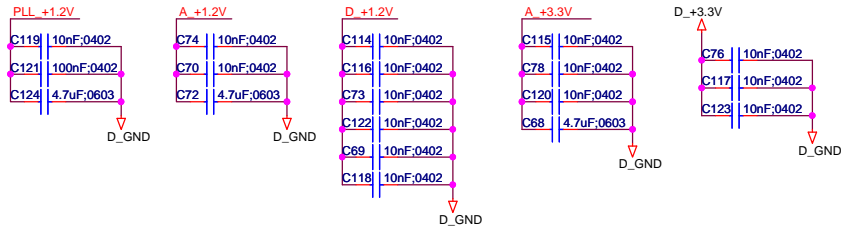
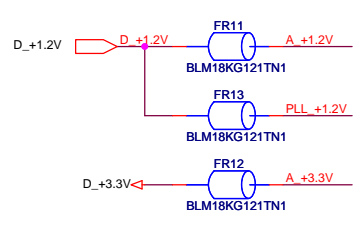

| | | |
|--------------------------------------------------------------------------------------|----------------------------------|----------|
| AK | | |
| Mobile Satellite Services 18221A Flower Hill Way Gaithersburg, MD 20879 USA | | |
| Title COM-5401 / LAN | | |
| Size B | Document Number Y10002 | Rev 0 |
| Date: Monday, April 12, 2010 | Sheet 6 | of 8 |

+5V Supply

Green Terminal Block
OPERATIONAL RANGE: 4.75 - 5.75V

Reverse Voltage Protection

Layout Note:
Q1 & Q2 must be placed and routed for a high current throughput.

Over Voltage Protection (5.85V)

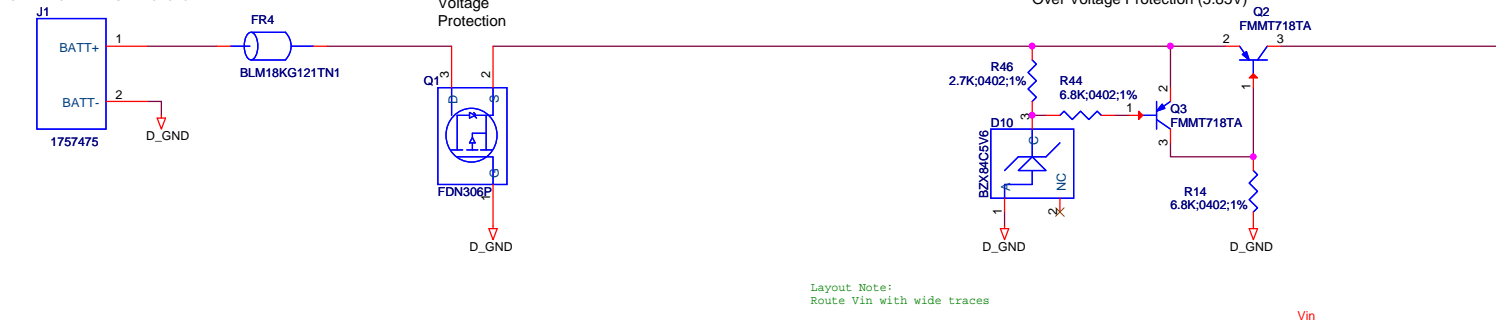

Layout Note:
Route Vin with wide traces

FAN2013B DC/DC converters:
2A max peak output current
1.2MHz switching

Layout Note: FAN2013 (x3)
Place Vin caps as close as possible to Vin and PGND pins

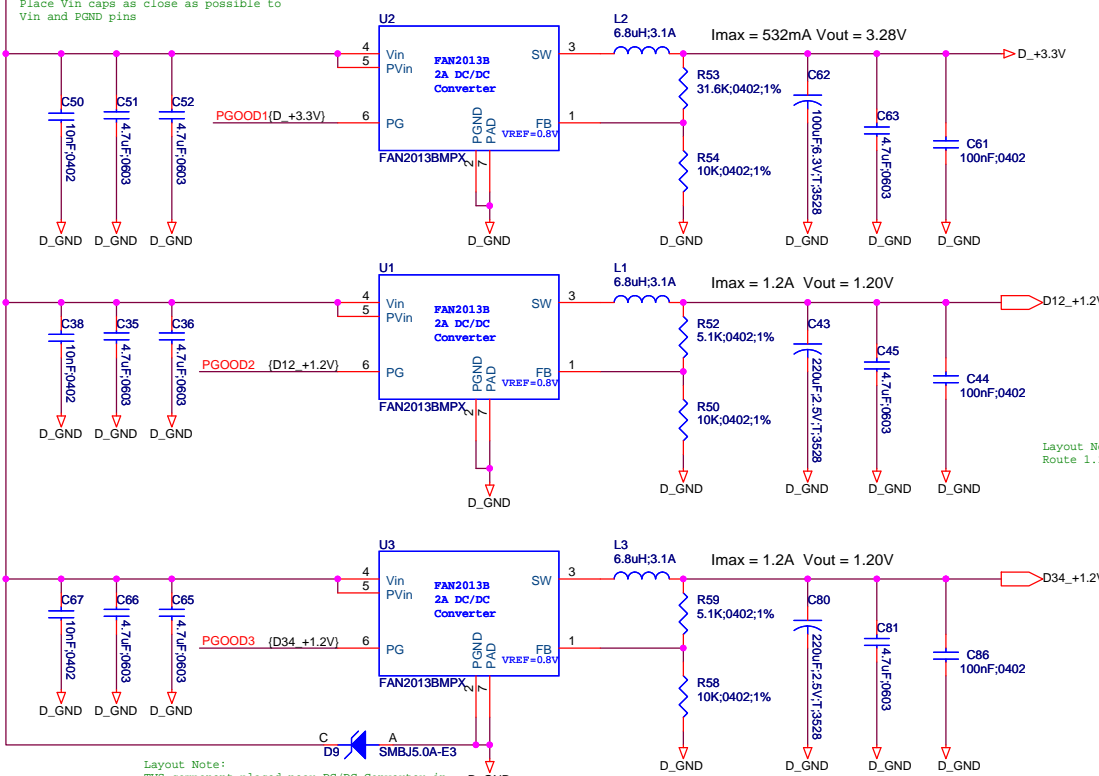
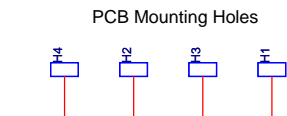
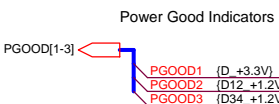

Layout Note:
Route 1.2V outputs with wide traces

Layout Note:
TVS component placed near DC/DC Converter in ground return path to terminal block

| | | |
|--------------------------------------------------------------------------------------------|----------------------------------|----------|
| AK Mobile Satellite Services 18221A Flower Hill Way Gaithersburg, MD 20879 USA | | |
| Title COM-5401 / POWER | | |
| Size B | Document Number Y10002 | Rev 0 |
| Date: Monday, April 12, 2010 | Sheet 7 | of 8 |

Layout Note:
All +/- pairs are 100 ohm Z differential traces

Layout Note:
Place RJ1 with 100 mil overhang beyond left board outline

Crystal Reference

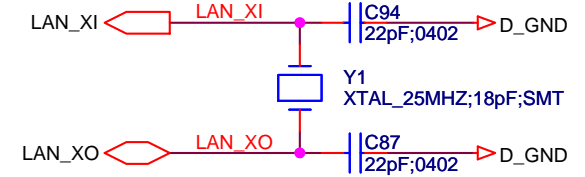

Chassis Grounding

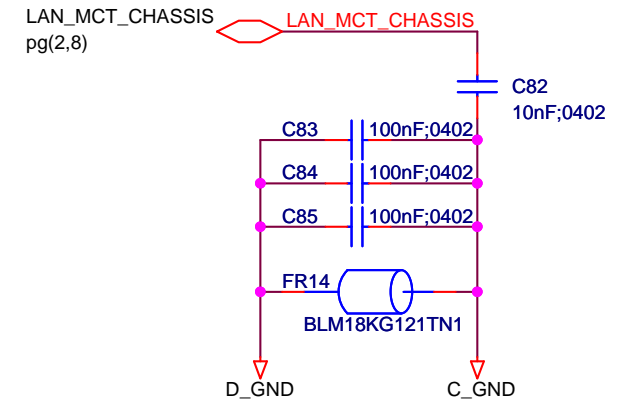

Layout Note:
Place ferrite bead close to RJ1

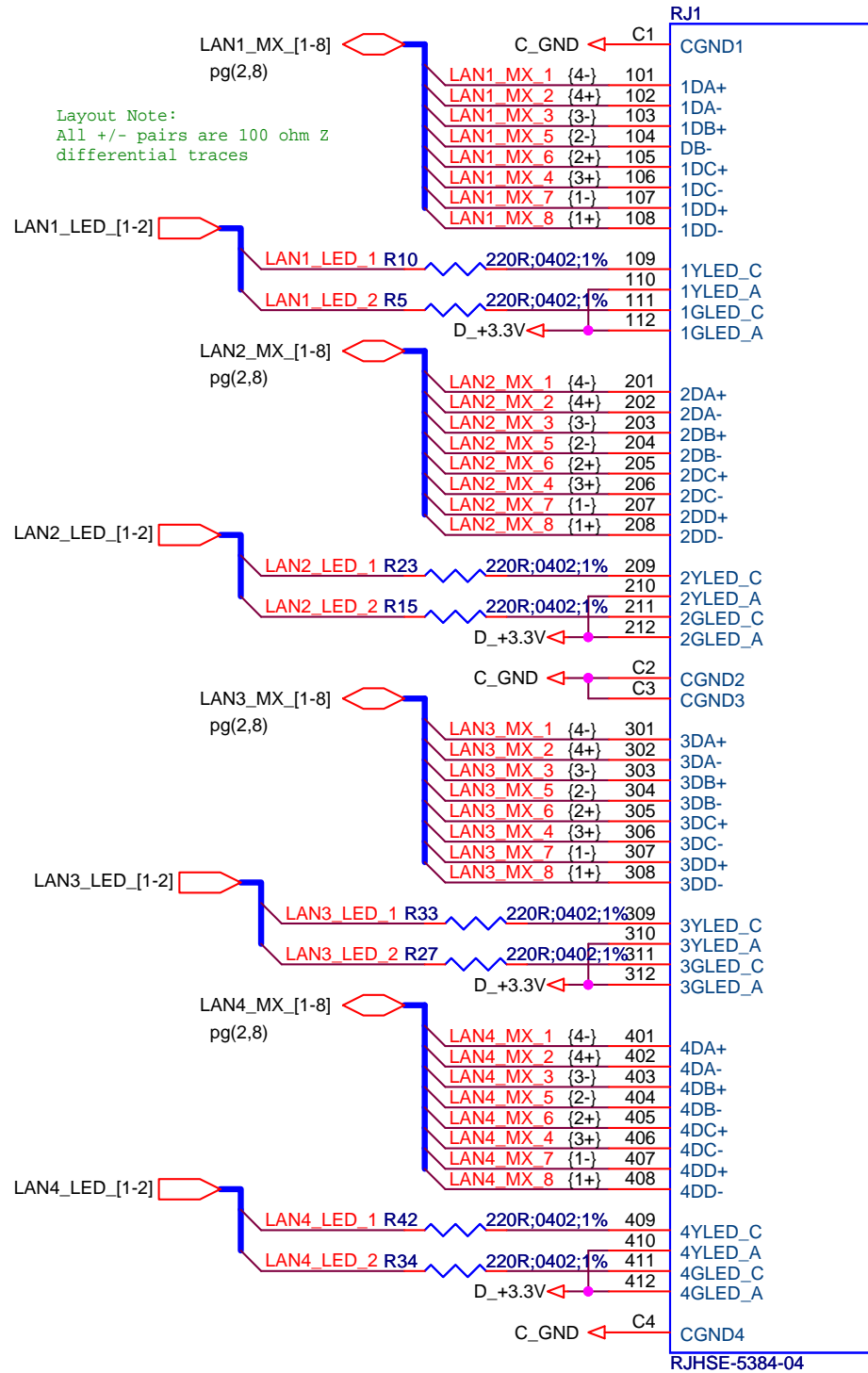

| | | |
|--------------------------------------------------------------------------------------|----------------------------------|----------|
| AK | | |
| Mobile Satellite Services 18221A Flower Hill Way Gaithersburg, MD 20879 USA | | |
| Title COM-5401 / RJ45 | | |
| Size A | Document Number Y10002 | Rev 0 |
| Date: Monday, April 12, 2010 | Sheet 8 | of 8 |